

# CONTENT

1. READING INSTRUCTIONS.....	01
2. START AND CHARGE SYSTEM.....	02
3. ABS SYSTEM.....	03
4. AIR CONDITIONING SYSTEM.....	04
5. AUDIO SYSTEM.....	05
6. AIR BAG SYSTEM.....	06
7. INSTRUMENT SYSTEM.....	07
8. ENGINE SYSTEM.....	08
9. FRONT ISU SYSTEM.....	09
10. FRONT ISU SYSTEM.....	10
11. REAR ISU SYSTEM.....	11
12. FUSES.....	12

---

## READING INSTRUCTIONS

1. NO. of relay circuit:

- 30 Coming from storage battery
- 15 Controlling by ignition switch
- ACC Ignition switch radio set
- 31 Ground
- 58b Luminous regulating line

2. This circuit diagram is suitable to configuration of A21 1.6 and 2.0. Considering the time limit, it is liable to mistakes or omissions. Please contact with Service Technology Dep. of sales company if any unconformity is found.

TEL 0553-5922392

FAX 0553-5840795

# START AND CHARGE SYSTEM

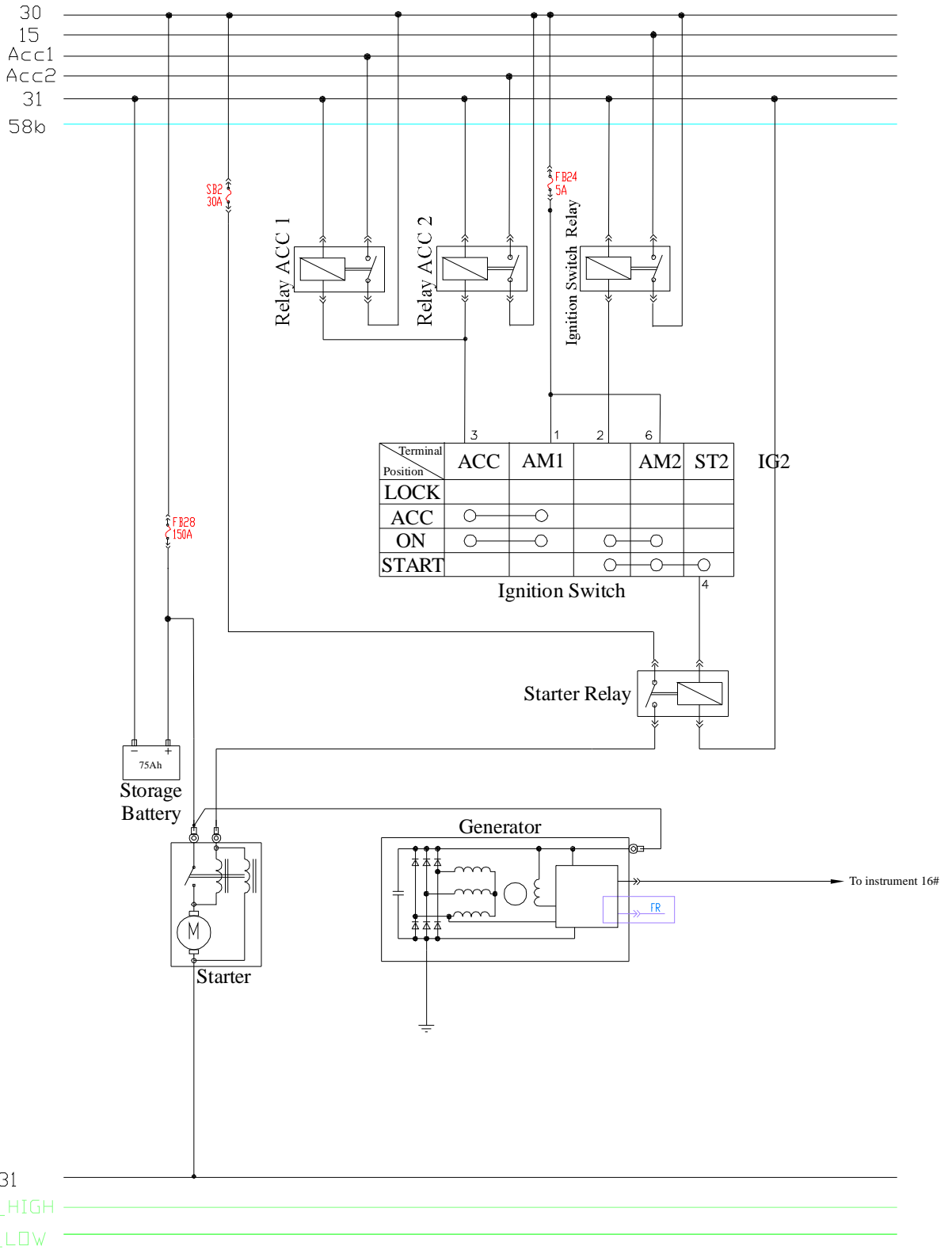

31  
CAN\_HIGH  
CAN\_LOW

# ABS SYSTEM

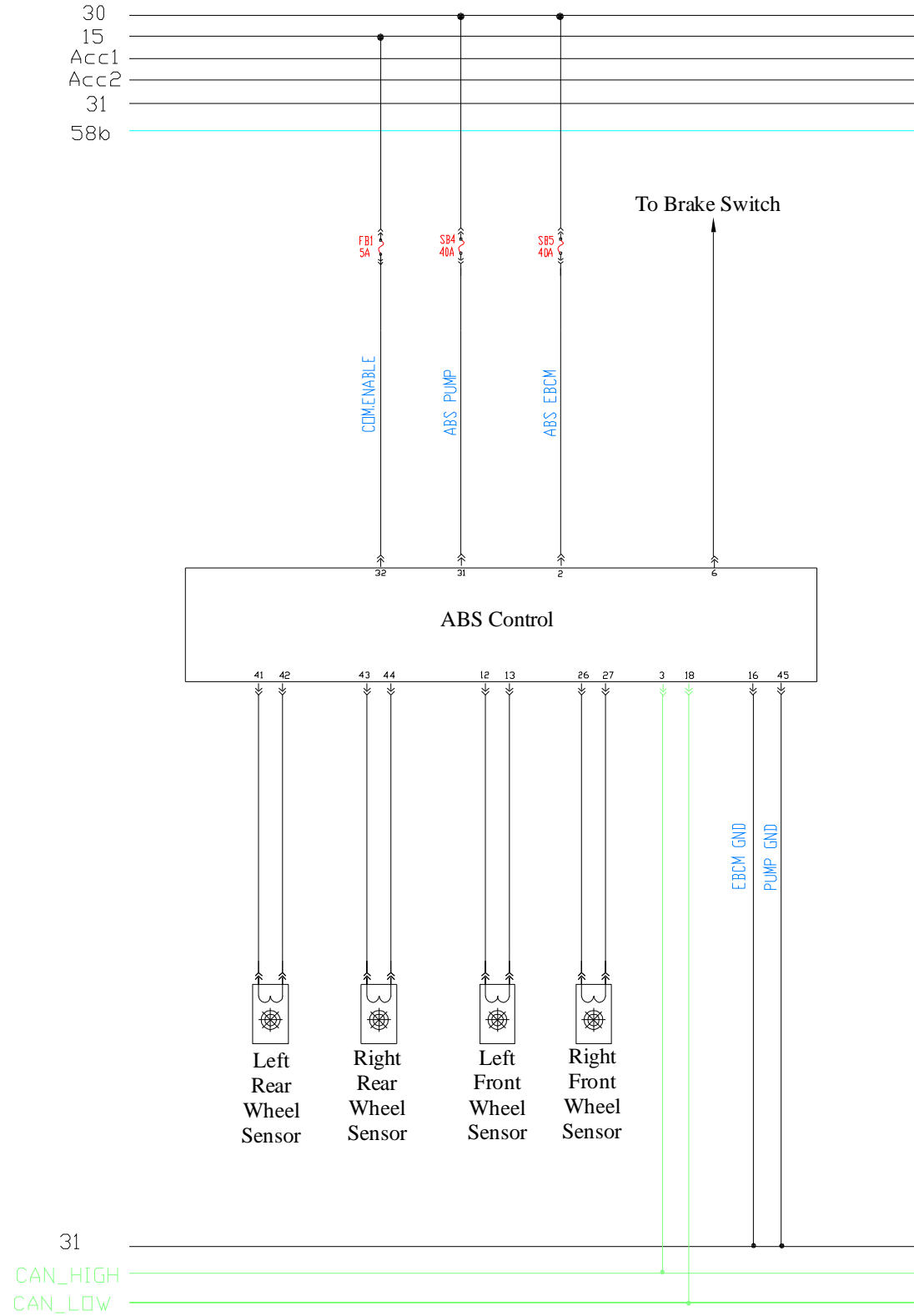

# AIR CONDITIONING SYSTEM

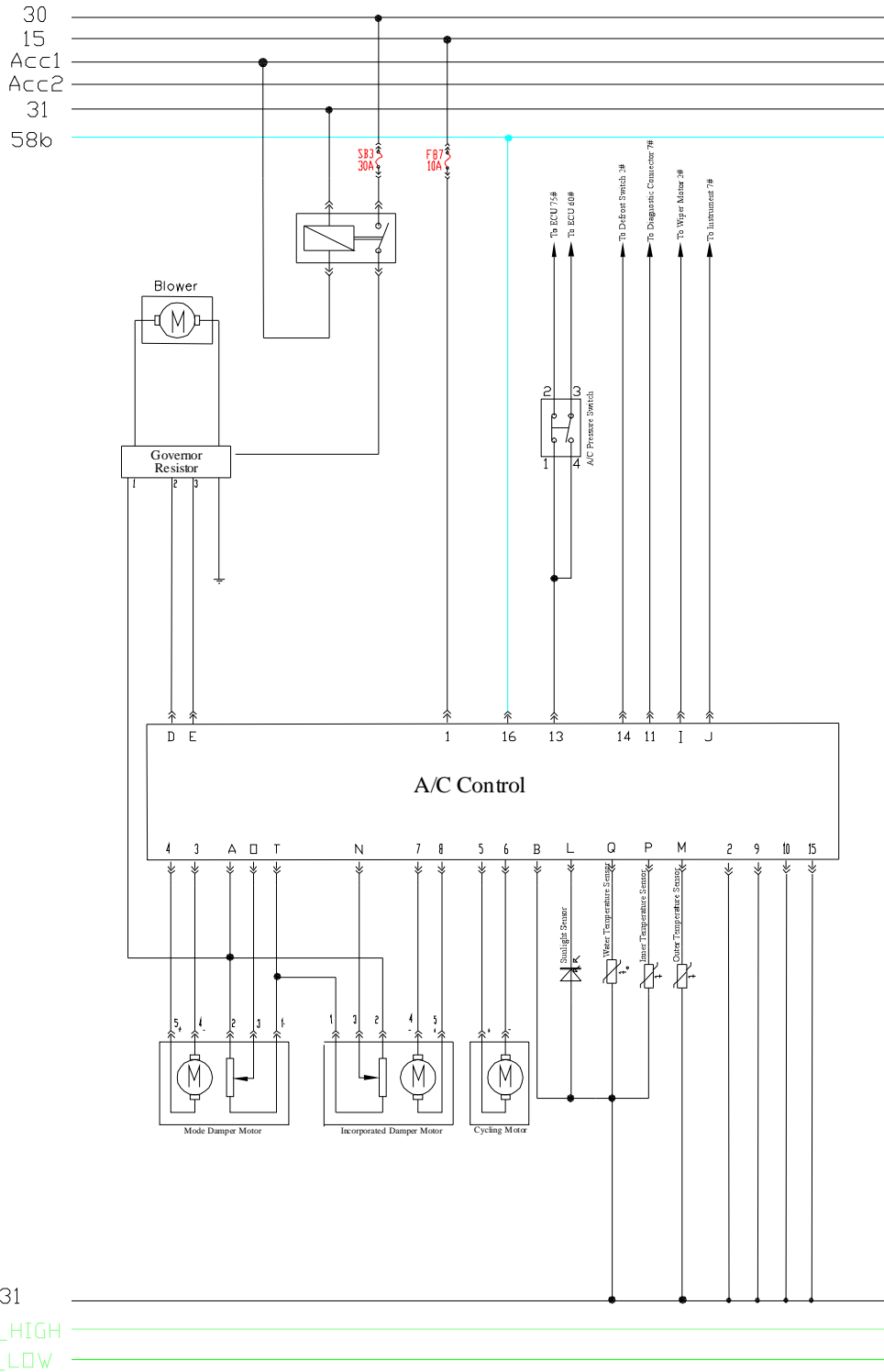

# AUDIO SYSTEM

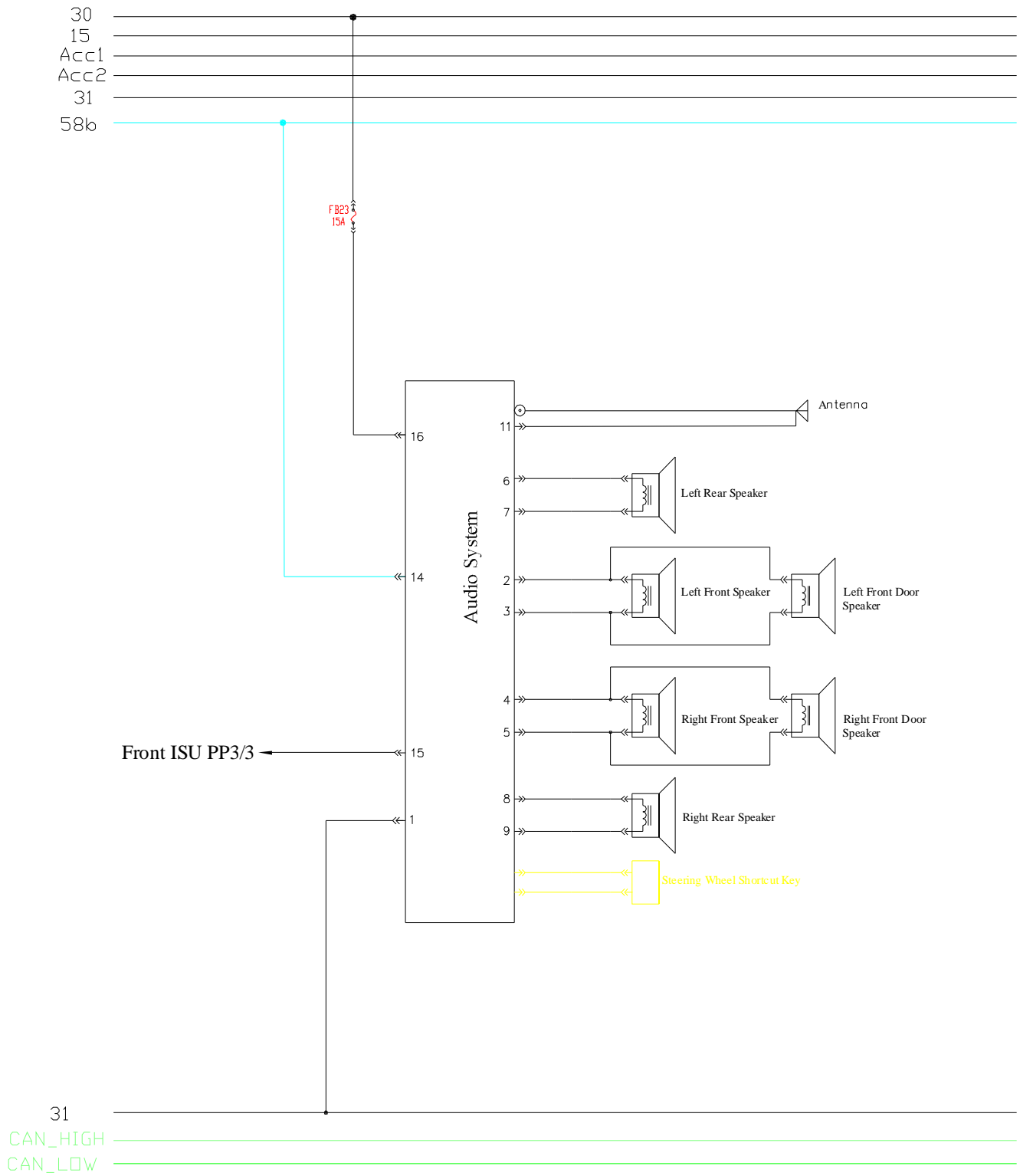



# AIR BAG SYSTEM

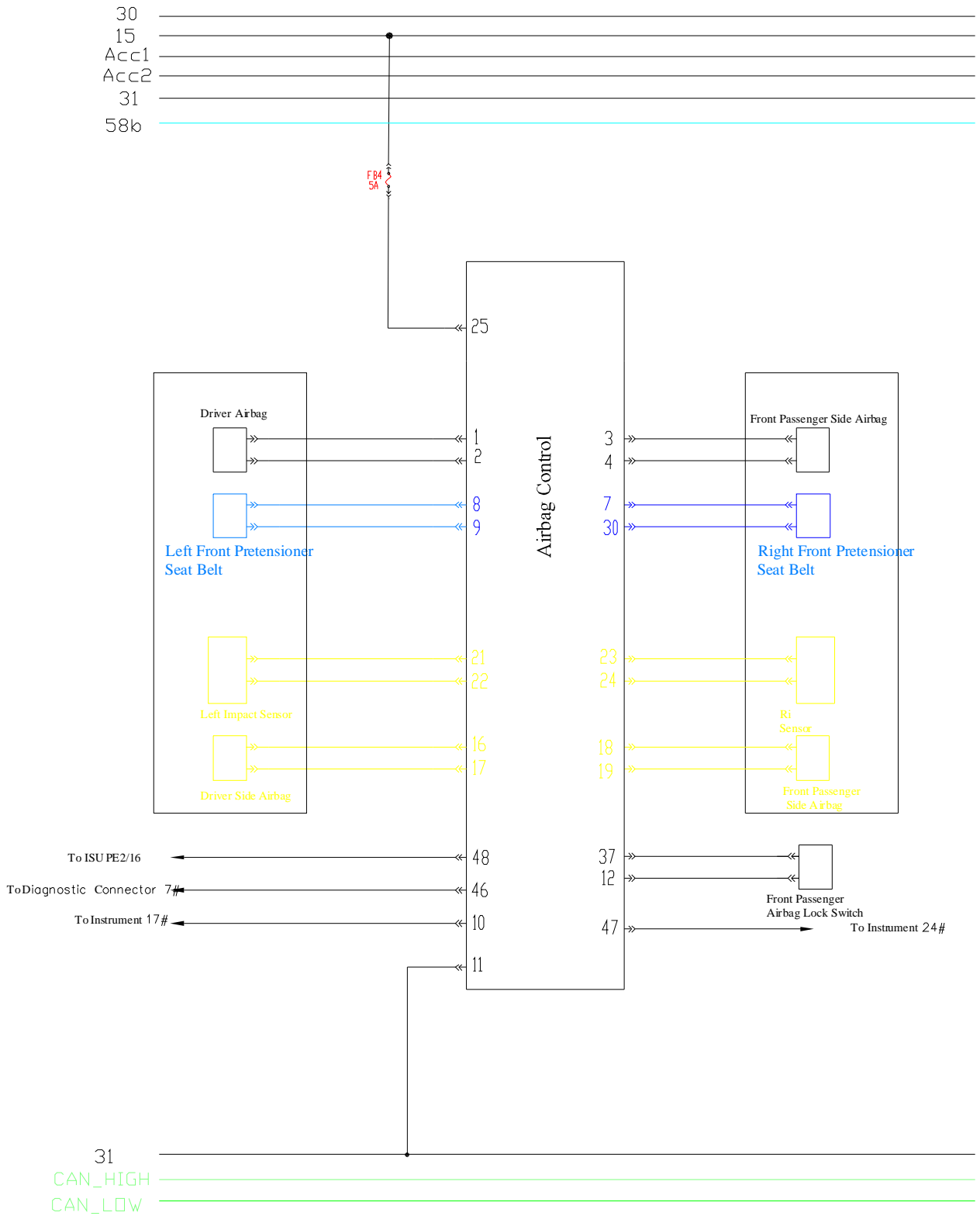



# INSTRUMENT SYSTEM

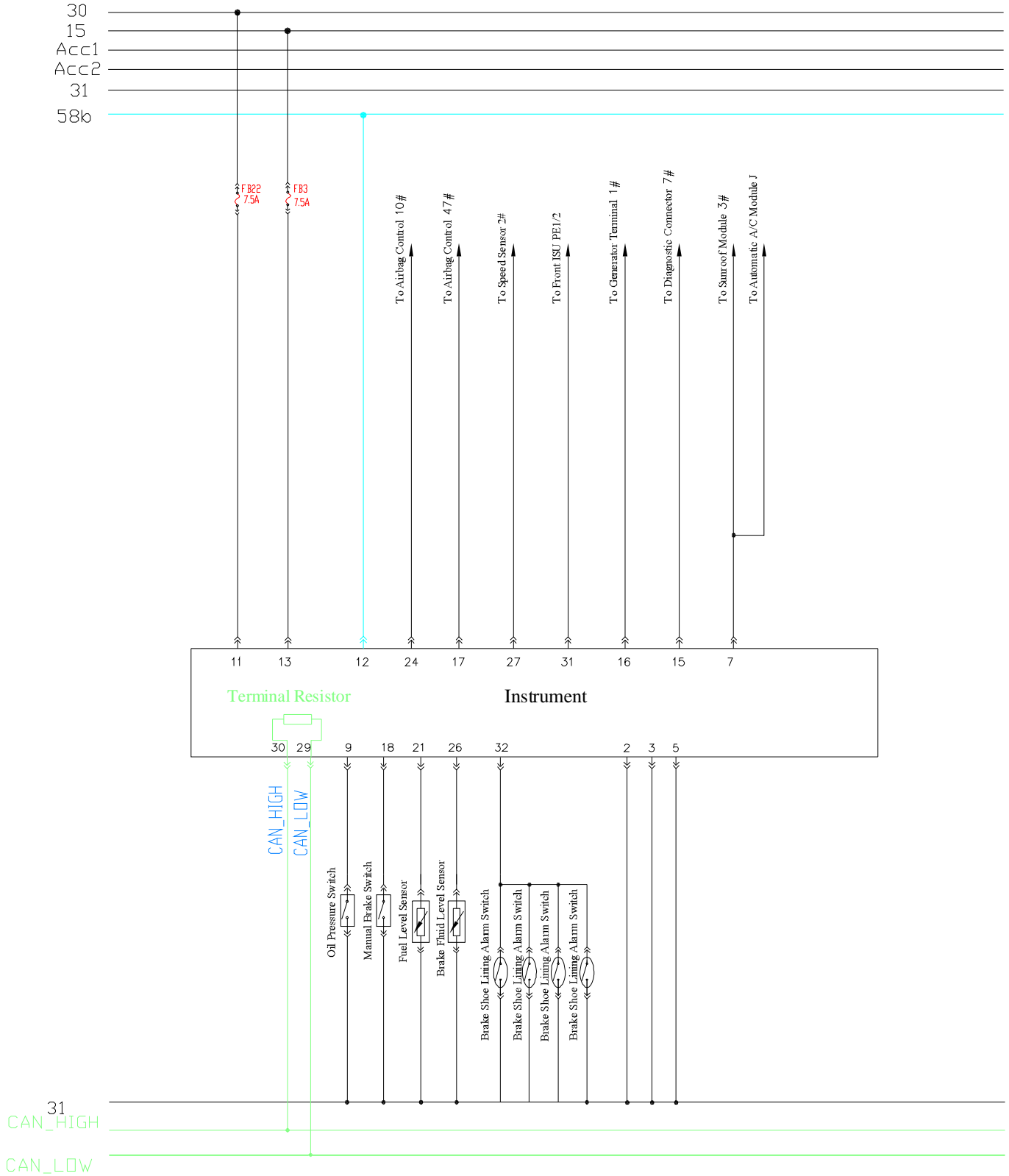



# FRONT ISU SYSTEM

CAN\_HIGH  
CAN\_LOW

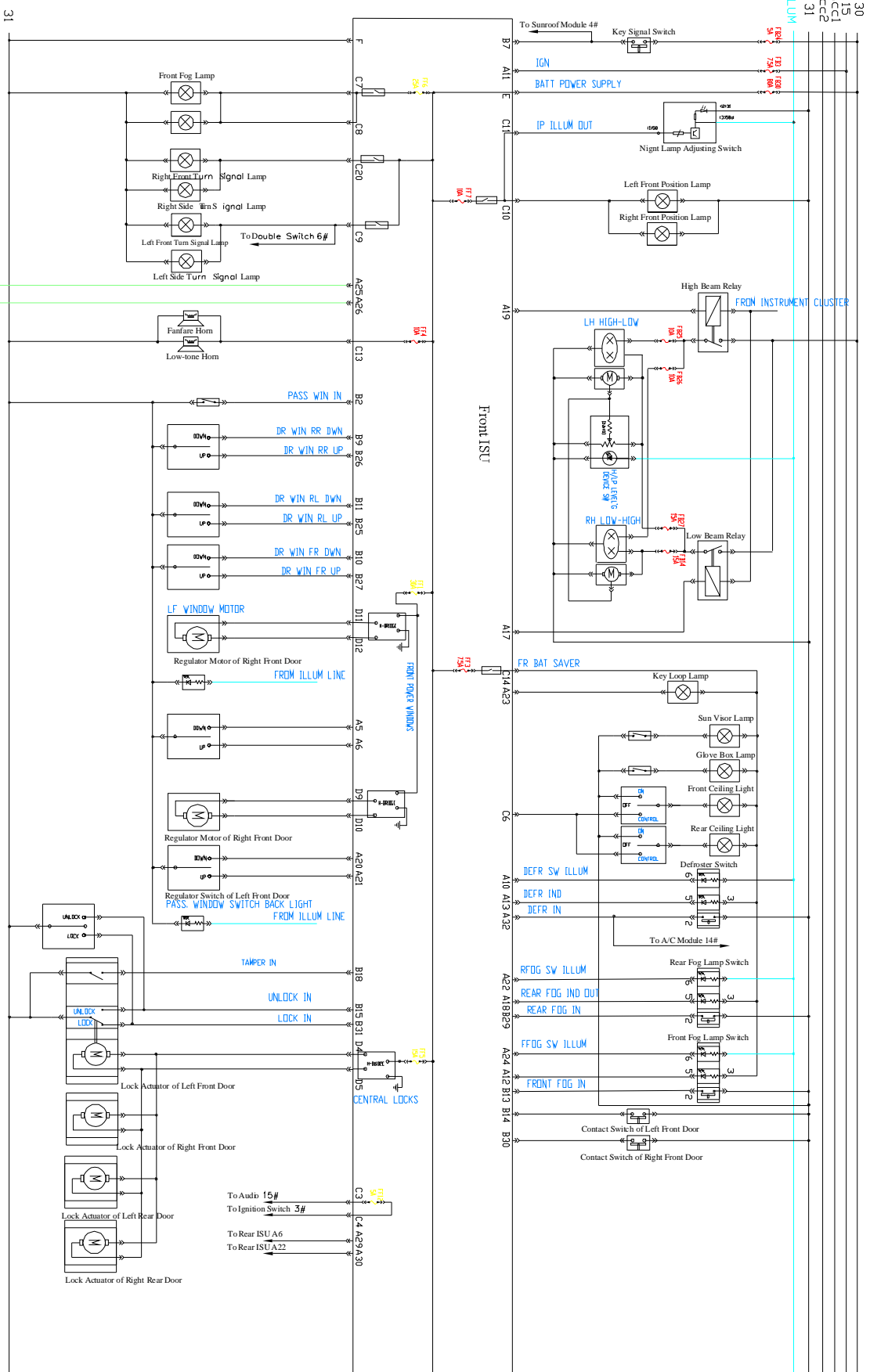





# FUSES

Storage battery fuse box (Блок предохранителей на аккумуляторе)

From the left to the right (слева от минуса аккумулятора, направо к плюсу):

- FB33 (40A) - Spare (запасной)
- FB32 (40A) - Cooling fans (вентиляторы радиатора)
- FB31 (50A) - Rear ISU (блок предохранителей в багажнике)
- FB30 (80A) - Front ISU (блок предохранителей в под рулевой колонкой)
- FB29 (80A) - Main Fuse Box (B+) (блок предохранителей под капотом)
- FB28 (150A) - Общий плюс всех цепей. Ignition Coil (катушка зажигания), Starter (стартер)

Main Fuse Box (Блок предохранителей под капотом)

